

# *Saving Danger, More Safe and Better Life*

**AIR RELEASE VALVE,  
AIR RELEASE & VACUUM BREAKER VALVE,  
COMBINATION AIR RELEASE & VACUUM BREAKER VALVE  
for WATER WORKS SYSTEM**



**ARV Series**

APPLICATION : AWWA - C512(American Water Works Association)

**PROSAVE**

# CONTENTS

- Air Release Valve
- Air Release & Vacuum Breaker Valve
- Combination Air Release & Vacuum Breaker Valve
- Vacuum Breaker Valve
- Others(Additional Option)
- Surge Pressure Relief / Control Valve
- Air Release Valve Sizing Calculation
- Technical Information



## **AIR RELEASE VALVE, AIR RELEASE & VACUUM BREAKER VALVE, COMBINATION AIR RELEASE & VACUUM BREAKER VALVE for WATER WORKS SYSTEM**



### **The definition of a term**

1. Air release valves, also called small orifice valves, are designed to automatically release small pockets of accumulated air from a pipeline while the system operates under pressure exceeding atmospheric pressure.
2. Air/vacuum valves, also called large orifice valves, are designed to exhaust large quantities of air automatically during pipeline filling and to admit large quantities of air automatically when the internal pressure in the pipeline drops below atmospheric pressure.
3. Combination air valves are designed to perform the same function as air/vacuum valves but, in addition, they will automatically release small pockets of air from the pipeline while under pressure, like an air release valve.

### **Rule being applied**

AWWA - C512 standard.  
(AWWA : American Water Works Association)

# Safety is our top priority at PROSAVE

PROSAVE's automatic Air Release Valve series are specifically designed to meet the requirements of water utility systems, greatly improving supply and distribution system efficiency.

We place special focus on ensuring that our products meet all applicable standards and specifications prescribed by the industry. From the most complex of applications to the simplest, our automatic Air Release Valve series perform with precision and accuracy to provide exact control of pressure, flow, level, surge and pump control.

## Classified Products

	MODEL	TYPE	OPTION	DESCRIPTION	ORIFICE	REMARK
Standard	ARL			Air Release Valve	Small	
	KSBJ			Air Release & Vacuum Breaker Valve	Large	
	CAV	D		Combination Air Release & Vacuum Breaker Valve	Dual (Small + large)	Dual Body
	CAV	S				Single Body
Standard + Option	KSBJ		C	Air Release & Vacuum Breaker Valve + Surge Check Valve	Large	
	CAV	D	C	Combination Air Release & Vacuum Breaker Valve + Surge Check Valve	Dual (Small + large)	Dual Body
	CAV	S	C			Single Body
	KSBJ		PR	Air Release & Vacuum Breaker + Pressure Relief Valve	Large	
	KSBJ		PV	Air Release & Vacuum Breaker + Pressure & Vacuum Relief Valve	Large	
	KSBJ		VB	Air Release & Vacuum Breaker + Vacuum Relief Valve	Large	
	KSVB			Vacuum Breaker Valve	N/A	
	SRV			Surge Pressure Relief Valve	N/A	

EX) **CAV - D - C - 04 - B148.C95800 - 150 lb R.F**



Combination Air Release & Vacuum Breaker with Surge Check Valve  
(Dual Orifice Type, ANSI 150 lb R.F)  
Material: NI-AL Bronze

## Air Release Valve



### Benefits

- Pressure relief function (exceeding atmospheric pressure)
- Liquid overflow protection
- Release small air pocket from pipeline
- Increasing of pump efficiency
- Less system energy
- Maintenance free

### Introduction

While the system is flowing and under pressure, air release valves continually and automatically exhaust the small quantities of air that would otherwise collect at system high points.

This ensures the system will remain free of trapped air (and sewage gases) thereby increasing system efficiency and reducing pumping cost.

### Installation

Air Release valve should be installed at high points or at grade changes within the pipeline.

### Dimension Table

Unit = mm

SIZE	ORIFICE	N.D	H	A
ARL-1/4"	1/32" ~ 1/4"	8	220 ~ 262	210
ARL-1/2"		15		
ARL-1"		25		
ARL-2"	1/2" ~ 1"	50	292	260

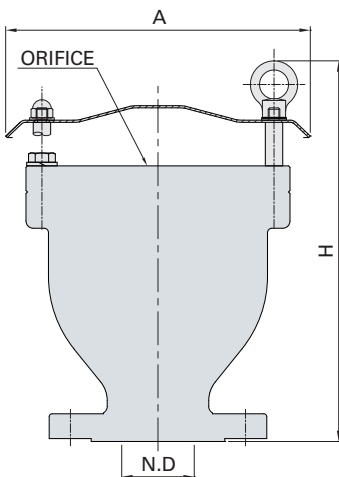

### Materials of Construction

No.	Description	Spec.1	Spec.2	Spec.3	Spec.4
1	BODY	Carbon Steel	Stainless Steel	Duplex Steel	Ni-Al Bronze
2	COVER	Carbon Steel	Stainless Steel	Duplex Steel	Ni-Al Bronze
3	FLOAT & DISC	Stainless Steel	Stainless Steel	Duplex Steel	Monel
4	BOLT / NUT	A193-B7 / A194 - 2H	A193-B8M / A194 - 8M	A193-B8M / A194 - 8M	A193-B8M / A194 - 8M

# KSBJ MODEL

## Air Release & Vacuum Breaker Valve

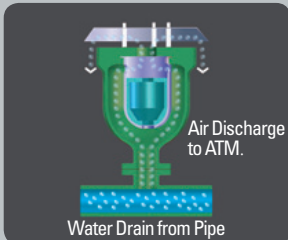

Activation 1 Pressure Relief

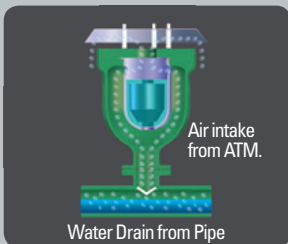

Activation 2 Vacuum Relief

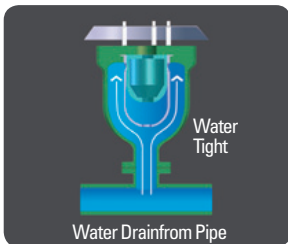

Activation 3 Liquid Overflow Protection



### Benefits

- Pressure & Vacuum relief function
- Anti-Surge & Anti-Shocks
- Surge and waterhammer protection
- Liquid overflow protection
- Provides high capacity venting for pipeline protection
- Increasing of pump efficiency
- Less system energy
- Maintenance free

It is two critical time in the operation of a pipeline.

During filling, air that occupies the empty pipe must be evacuated ahead of the incoming liquid in a controlled and efficient manner so that surge and water hammer are minimized and liquid completely fills the pipe. During draining, whether planned or unexpected, air must be admitted into the system to replace the out flowing liquid to avoid excessive vacuum and possible pipeline damage.

Air release valve are designed to release accumulated air pockets from the system, while pressured pipelines. Air pockets increase energy consumption because pumping operation will be at higher water heads to overcome pressured air.

Air release valves are have function to protect high shock and surge pressure, water hammer and liquid overflow from fresh or sea water pipelines.

PROSAVE's valve can provide low cast insurance to protect expensive maintenance cost of pipelines and pump systems.

### Dimension Table

Unit = mm

SIZE	1"	1 1/2"	2"	2 1/2"	3"	4"	6"	8"	10"	12"	14"
N.D	25	40	50	65	80	100	150	200	250	300	350
ØA	170	170	170	210	210	260	340	460	565	635	760
H	235	252	252	272	297	327	392	479	750	845	949

Note: Standard flange connection is ANSI 150 lb and others are available on request.

### Materials of Construction

No.	Description	Material		
		Spec. 1	Spec. 2	Spec. 3
1	Body	A216-WCB	B148-C95800	A351-CF3M
2	Float & Disc	A240-316L	MONEL	A240-316L
3	Seat	NBR	NBR	NBR

#### NOTICE !!

Air Release Valve & Vacuum Breaker Valves can be add another function such as Anti-surge, pressure/vacuum relief in according to operation condition. In this case, You can make good choice PROSAVE's verious model.

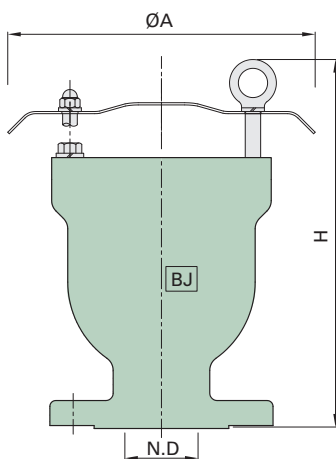

# Combination Air Release & Vacuum Breaker Valve



**Dual Body**

### Benefits

- Pressure & Vacuum relief function
- Anti-Surge & Anti-Shocks
- Surge and waterhammer protection
- Liquid overflow protection
- Provides high capacity venting for pipeline protection
- Increasing of pump efficiency
- Less system energy
- Maintenance free
- Release small pockets under operation pressure



**Single Body**

### Introduction

Combination air valves are normally installed at high points where air would naturally rise ahead of the incoming liquid during filling and collect during operation and/or where negative pressure first occurs during draining.

The large (air & vacuum) and the small (air release) orifices are both open during filling with the majority of the air is passes through the large orifice.

The rate at which air is discharged is a function of the differential pressure across the air & vacuum valve.

During filling, incoming water compresses the air in the "empty" pipe until the pressure differential across the air valve is sufficient that air is discharged at the same volumetric rate as water is entering the pipe.

After all the air has been purged, liquid enters the valve and lifts the floats and closes both orifices.

While the large orifice remains closed, the small orifice reopens as necessary to release any air that collects in the valve after it has closed. Should the internal pressure fall below atmospheric, both orifices open to allow air to flow through the valve into the system at the same volumetric rate at which the liquid is draining thus avoiding critical vacuum and damage to the pipe.

## CAV-D MODEL

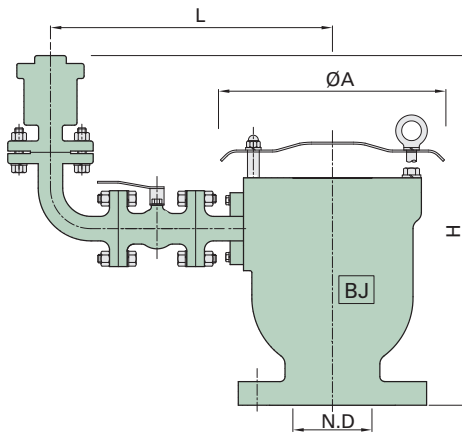

### Dimension Table

Unit = mm

SIZE	2"	3"	4"	6"	8"	10"	10"	12"
N.D	50	80	100	150	200	250	300	350
ØA	170	210	260	340	460	565	635	760
H	340	370	380	435	494	750	845	949
L	305	330	350	383	420	473	498	553

Note: Standard flange connection is ANSI 150 lb and others are available on request.

### Materials of Construction

No.	Description	Material		
		Spec. 1	Spec. 2	Spec. 3
1	Air Release Valve			
1-1	Body	A216-WCB	B148-C95800	A351-CF3M
1-2	Float & Disc	HDPE	HDPE	HDPE
1-3	Seat	NBR	NBR	NBR
2	Air Release & Vacuum Breaker Valve			
2-1	Body	A216-WCB	B148-C95800	A351-CF3M
2-2	Cover	SS400	B148-C95800	A351-CF3M
2-3	Ball	A240-316L	Monel-K400	A240-316L
2-4	Gasket	NBR	NBR	NBR

**NOTICE !!**

Air Release Valve & Vacuum Breaker Valves can be add another function such as Anti-surge, pressure/vacuum relief in according to operation condition. In this case, You can make good choice PROSAVE's verious model.

## CAV-S MODEL

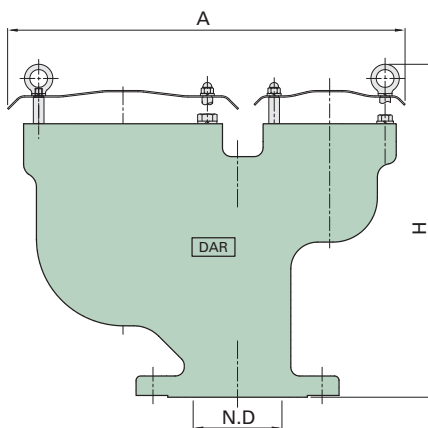

### Dimension Table

Unit = mm

SIZE	4"	6"	8"	10"	12"	14"
N.D	100	150	200	250	300	350
ØA	448	520	650	760	840	950
H	375	450	550	820	920	1050

Note: Standard flange connection is ANSI 150 lb and others are available on request.

### Materials of Construction

No.	Description	Material		
		Spec. 1	Spec. 2	Spec. 3
1	Body	A216-WCB	B148-C95800	A351-CF3M
2	Float & Disc	HDPE	HDPE	HDPE
3	Seat	NBR	NBR	NBR

**NOTICE !!**

Air Release Valve & Vacuum Breaker Valves can be add another function such as Anti-surge, pressure/vacuum relief in according to operation condition. In this case, You can make good choice PROSAVE's verious model.

## Vacuum Breaker Valve



### Benefits

Designed manufactured and tested according to the API 2000 code.

Utilize the latest technologies to provide protection against positive or vacuum over pressure and prevent air intake, evaporative losses of product and help to contain odorous and potentially explosive vapours.

### Introduction

The KSVB is a spring loaded model, designed to handle under pressure with a minimum pressure of -150mmW.C and maximum setting of -7,000mmW.C.

Body material are available in Aluminium, Carbon Steel, 304SS,316SS and Ni-Al Bronze with various trims to suit individual requirements.

Sizes range from 50mm through to 300mm with ANSI 150lb FF flanges as standard. (Different connections available on request).

### Dimension Table

SIZE	1"	2"	3"	4"	6"	8"	10"	12"	16"	Other Size
N.D	25	50	80	100	150	200	250	300	400	Available on request
ØA	252	330	440	440	440	550	620	620	650	
H	270	333	380	395	405	430	523	558	500	

Note: Standard flange connection is ANSI 150 lb and others are available on request.

### Materials of Construction

No.	Description	Material		
		Spec. 1	Spec. 2	Spec. 3
1	Body	Carbon Steel	Ni-Al Bronze	Stainless Steel
2	Vacuum Seat	Carbon Steel	Ni-Al Bronze	Stainless Steel
3	Vacuum Disc	Carbon Steel	Ni-Al Bronze	Stainless Steel
4	Spring	A167-316	Inconel	A167-316
5	Hood	Steel	SUS316	SUS316

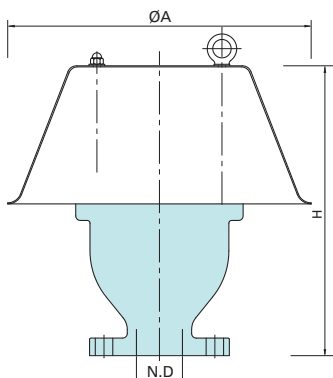



## Others

# Additional Option for a variety of applications

### Air release & Vacuum Breaker with Surge Check Valve

#### Benefits

- Designed to perform the same function as Air Release & Vacuum Breaker Valve.
- Reinforced the function of protection for surge pressure
- Usually to be applied more than the 4" valve size which it needed for large capacity pump.



**KSBJ-C**

### Combination Air release & Vacuum Breaker with Surge Check Valve

#### Benefits

- Designed to perform the same function as Combination Air Release & Vacuum Breaker Valve.
- Reinforced the function of protection for surge pressure
- Usually to be applied more than the 4" valve size which it needed for large capacity pump.



**CAV-S-C**



**CAV-D-C**

### Air Release valve with Vacuum Breaker Valve

#### Benefits

- Designed to perform the same function as air release valves.
- Reinforced the function of vacuum breaker
- Usually to be applied that it is for large inhalation of air & small exhaust of air at once



**VB-AR**

### Air Release & Vacuum Breaker with Pressure / Vacuum Relief Valve

#### Benefits

- Designed to perform the same function as Air Release & Vacuum Breaker Valve.
- Added the function of setting pressure & vacuum
- Adjustable air flow capacity and different pressure in pipe line



**KSBJ-VB**



**KSBJ-PR**

## SRV MODEL

# Surge Pressure Relief / Control Valve

### Benefits

- **Quick response**

The high-capacity proportional hydraulic design allows fast response to surge pressure. This results in prompt return to stable pressure conditions.

- **Low-maintenance**

Due to the absence of any external gas supply such as gas bottle, maintenance is reduced to the bare minimum, making the valve ideal for remote or inaccessible locations.

- **High-performance**

Surge valve designs are based on simplicity. All components are field-proven to provide maximum protection reliability. They operate solely on fluid static pressure.

- **Stable operation**

The design of the hydraulic incorporates snap-acting opening when the set pressure is reached and automatic switching to control in the event of continuing high-pressure conditions.



### Introduction

Surge Relief Valves consist of a main valve assembly and Hydraulic Actuator, Accessory, completely assembled and tested as a unit and ready for field installation.

The valves are open when system pressure exceeds its pressure setting and throttle as necessary to limit system pressure to a pre-set maximum pressure. When pressure subsides below the pre-set maximum the valves are close tight.

### Typical Installation

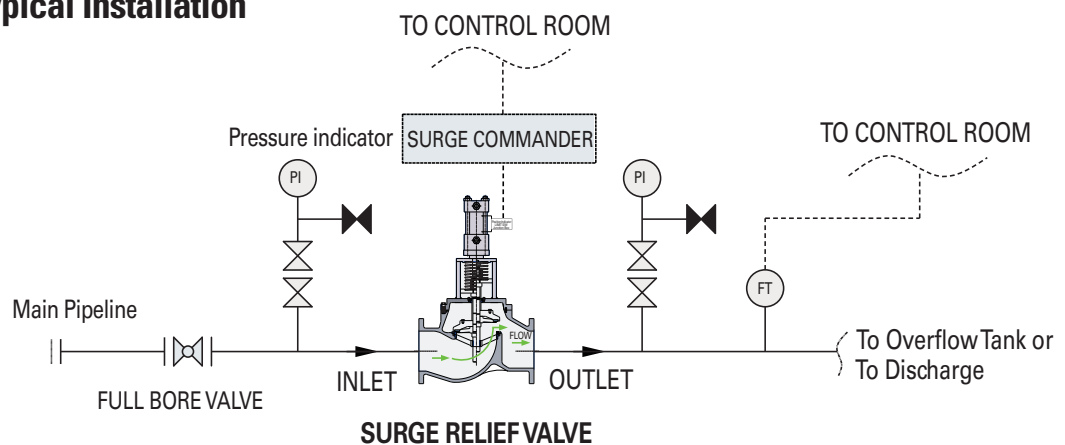

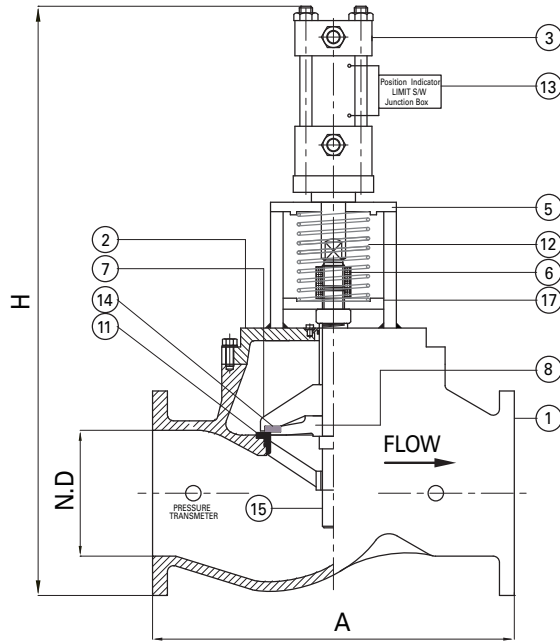

### SURGE COMMANDER

Enclosure : Corrosion resistant  
 Dimension : 400(H) x 450(W) x 230(D)  
 Input Power : 24VAC  
 Out Power : 24VDC from internal battery, charger

### Dimension Table

Unit = mm

SIZE	2"	3"	4"	6"	8"	10"	12"	16"	20"	24"	Other Size
N.D	50	80	100	150	200	250	300	400	500	600	Available on request
A	275	300	375	500	635	744	850	1035	1178	1250	
H	800	800	900	1000	1200	1400	1600	1900	2200	2500	

Note: Standard flange connection is JIS 5K and others are available on request.

### Materials of Construction

1	BODY	ASTM A216 Gr. WCB
2	BONET(COVER)	ASTM A216 Gr. WCB
3	HYDRAULIC ACTUATOR	STEEL
5	CYLINDER FLANGE PLATE	S.S. TYPE 316
6	COUPLING JOINT	STEEL COMM'L
7	DISK	S.S TYPE 316
8	DISK RETAINER	S.S TYPE 316
9	STEM SEAL	BUNA-N
11	SEAT RING	S.S TYPE 316
12	SPRING	STEEL
13	POSITION INDICATOR	STEEL COMM'L
14	RESILIENT DISK	EPDM
15	STEM	S.S TYPE 316
17	SPRING GUIDE	STEEL COMM'L

## Sizing Calculation

# Air Release Valve Sizing Calculation

Where ;

- I : At transition points in pipe slope, particularly before and after steep slopes
- II : On long rising or falling pipe lengths
- III : At local peaks in the system

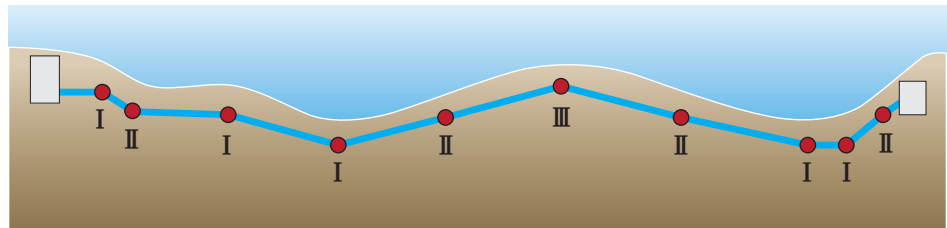

### Air Release & Air / Vacuum Breaker Valve(Including Combination Type) Sizing

1. Air and vacuum Valves should be sized to handle the maximum amount of air to be exhausted or admitted into the pipeline and not exceed an acceptable pressure differential across the valve.
2. Air and vacuum Valves should be not exceeding a pressure differential of 2 psi across the valve orifice. (Based on pump capacity)

The following formula is recommended to calculate the rate of flow in CFR for filling the pipeline;

$$CFR = \frac{GMP}{\partial}$$

Where ;

- CFR = Calculate Flow Rate (ft<sup>3</sup>/sec)
- GMP = Gallons per minute
- $\partial$  = 448.83

3. Determine the smallest valve size capable of admitting air equal to the potential flow in CFR while not exceeding a pressure differential of 5 psi across the valve orifice. (Based on gravity flow).

The following formula should be used to calculate the rate of flow in CFR that can occur within the pipeline under gravity flow conditions. (During initial filling, During intentional draining, During a pipeline rupture)

$$Q = \alpha C \sqrt{SD^5}$$

Where ;

- Q = Flow of water in cubic feet per second
- $\alpha$  = Constant(0.0007872)
- C = coefficient in Chezy's formula(110)
- S = Slope in feet per foot or length
- D = Inside pipe diameter in inches

4. If thin wall pipe is being used, the risk of pipeline collapse due the formation of vacuum must be considered.

The following formula may be used to calculate the collapsing pressure of thin walled cylindrical steel pipe using a safety factor of four;

$$P = \beta \left( \frac{T}{D} \right)^3$$

Where ;

- P = Collapsing Pressure in psi
- $\beta$  = Constant(16250000)
- T = Thickness of pipe in inches
- D = Diameter of pipe in inches

5. For other pipe materials or thickness consult pipe manufacturer for pipe collapsing pressure.
6. Determine the smallest valve size capable of admitting the required air in CFR without exceeding the collapsing pressure or 5 psi, whichever is less. Do not exceed a pressure differential greater than 5psi.
7. Finally compare the valve size determined in step 3 with the valve size determined in steps 4 or 5 . If they differ, always select the larger valve size.

# Technical Information

## Unit Conversion Table

### Length

	mm	cm	m	km	inch	feet	yard	mile
mm	1	0.1	0.0001	0.0000001	0.039370079	0.003280827	0.001093598	6.21164E-07
cm	10	1	0.01	0.00001	0.393700787	0.032808268	0.01093598	6.21164E-06
m	1000	100	1	0.001	39.37007874	3.280826772	1.093597988	0.000621164
km	1000000	100000	1000	1	39370.07874	3280.826772	1093.597988	0.621163657
inch	25.4	2.54	0.0254	0.0000254	1	0.083333	0.027777389	1.57776E-05
feet	304.8	30.48	0.3048	0.0003048	12	1	0.33333	0.000189331
yard	914.4	91.44	0.9144	0.0009144	36	3	1	0.000568
mile	1609344	160934.4	1609.344	1.609344	63360	5280	1760	1

### Area

	cm <sup>2</sup>	m <sup>2</sup>	km <sup>2</sup>	in <sup>2</sup>	ft <sup>2</sup>	yd <sup>2</sup>	acre	mile <sup>2</sup>
cm <sup>2</sup>	1	0.0001	1E-10	0.15500031	0.001076385	1.19596E-06	-	-
m <sup>2</sup>	10000	1	0.000001	1550.00312	10.76382449	1.195956586	0.000247105	-
km <sup>2</sup>	10000000000	1000000	1	1550003120	10763824.49	1195956.586	247.105	0.385844342
in <sup>2</sup>	6.4516	0.00064516	6.4516E-10	1	0.006944389	0.000771584	-	-
ft <sup>2</sup>	929.0304	0.09290304	9.2903E-08	144	1	0.111111111	0.000023	3.58345E-08
yd <sup>2</sup>	8361.2736	0.83612736	8.36127E-07	1296	9	1	0.0002066	3.22624E-07
acre	-	4046.86	0.004047	-	43560	4840	1	0.001562
mile <sup>2</sup>	25899881103	2589988.11	2.58998811	4014489600	27878400	3097600	640	1

### Weight

	kg	ton	lb	UK cwt	UK ton	US cwt	US ton
kg	1	0.001	2.20462	0.019684	0.000984	0.022046	0.001102
ton	1000	1	2204.62	19.6841	0.984207	22.0462	1.10231
lb	0.453592	0.000453592	1	0.008929	0.000446	0.01	0.0005
UK cwt	50.8023	0.0508023	112	1	0.05	1.12	0.056
UK ton	1016.05	1.01605	2240	20	1	22.4	1.12
US cwt	45.3592	0.045359	100	0.892857	0.044643	1	0.05
US ton	907.185	0.907185	2000	17.8571	0.892857	20	1

### Pressure

	atmos	mm-Hg	m-bar	bar	pascal	in H2O	in Hg	psi
atmos	1	760	1013.25	1.01325	101325	406.781	29.9213	14.6959
mm-Hg	0.0013158	1	1.33322	0.001333	133.322	0.53524	0.03937	0.019337
m-bar	0.0009869	0.750062	1	0.001	100	0.401463	0.02953	0.014504
bar	0.9869	750.062	1000	1	100000	401.463	29.53	14.504
pascal	0.0000099	0.007501	0.01	0.00001	1	0.004015	0.0002953	0.000145
in H2O	0.0024583	1.86832	2.49089	0.002491	249.089	1	0.073556	0.036127
in Hg	0.033421	25.4	33.8639	0.0338639	3386.39	13.5951	1	0.491154
psi	0.068046	51.7149	68.9476	0.0689476	6894.76	27.6799	2.03602	1

### Flow Rate

	L/s	L/min	cm <sup>3</sup> /s	m <sup>3</sup> /hr	ft <sup>3</sup> /min	gal/min
L/s	1	60	1000	3.6	2.11887	15.851
L/min	0.016667	1	16.6667	0.06	0.035314	0.26418
cm <sup>3</sup> /s	0.001	0.06	1	0.0036	0.002119	0.01585
m <sup>3</sup> /hr	0.277778	16.6667	277.778	1	0.588575	4.40295
ft <sup>3</sup> /min	0.47195	28.317	471.95	1.69902	1	7.4807
gal/min	0.063089	3.78534	63.089	0.22712	0.131677	1

# Technical Information

## Rating Explanation

<b>1</b> Good	<b>2</b> Be careful
<b>3</b> Not useable	<b>na</b> No information

# Corrosion Resistance Table

Fluid	Metal											
	Carbon Steel	Cast Iron	302 and 304 Stainless Steel	316 Stainless Steel	Bronze	Alloy20	Monel	Hasteloy B	Hasteloy C	Titanium	Cobalt base alloy 6	416 Stainless Steel
Acetaldehyde	1	1	1	1	1	1	1	na	1	na	na	1
Acetic acid, air free	3	3	2	2	2	1	2	1	1	1	1	3
Acetic acid, aerated	3	3	1	1	1	1	1	1	1	1	1	3
Acetic acid, vapors	3	3	1	1	2	2	2	na	1	1	1	3
Acetone	1	1	1	1	1	1	1	1	1	1	1	1
Acetylene	1	1	1	1		1	1	1	1	na	1	1
Alcohols	1	1		1	1	1	1	1	1	1	1	1
Aluminium Sulfate	3	3	1	1	2	1	2	1	1	1	na	3
Ammonia	1	1	1	1	3	1	3	1	1	1	1	1
Ammonium chloride	3	3	2	2	2	1	2	1	1	1	2	3
Ammonium Nitrate	1	3	1	1	3	1	3	1	1	1	1	3
Ammonium Phosphate	4	3	1	1	2	2	2	1	1	1	1	2
Ammonium Sulfate	3	3	2	1	2	1	1	1	1	1	1	3
Ammonium Sulfite	3	3	1	1	3	1	3	na	1	1	1	2
Aniline	3	3	1	1	3	1	2	1	1	1	1	3
Asphalt	1	1	1	1	1	1	1	1	1	na	1	1
Beer	2	2	1	1	2	1	1	1	1	1	1	2
Benzene (benzol)	1	1	1	1	1	1	1	1	1	1	1	1
Benzoic acid	3	3	1	1	1	1	1		1	1		1
Boric acid	3	3	1	1	1	1	1	1	1	1	1	2
Butane	1	1	1	1	1	1	1	1	1		1	1
Calcium Chloride (alkaline)	2	2	3	2	3	1	1	1	1	1	na	3
Calcium hypochlorite	3	3	2	2	2	1	2	3	1	1	na	3
Carbolic acid	2	2	1	1	1	1	1	1	1	1	1	
Carbon dioxide, dry	1	1	1	1	1	1	1	1	1	1	1	1
Carbon dioxide, wet	3	3	1	1	2	1	1	1	1	1	1	1
Carbon disulfide	1	1	1	1	3	1	2	1	1	1	1	2
Carbon tetrachloride	2	2	2	2	1	1	1	2	1	1	na	3
Carbonic acid	3	3	2	2	2	1	1	1	1			1
Chlorine gas	1	1	2	2	2	1	1	1	1	3	2	3
Chlorine gas, wet	3	3	3	3	3	3	3	3	2	1	2	3
Chlorine, liquid	3	3	3	3	2	2	3	3	1	3	2	3
Chromic acid	3	3	3	2	3	3	1	3	1	1	2	3
Citric acid		3	2	1	1	1	2	1	1	1		2
Coke oven gas	1	1	1	1	2	1	2	1	1	1	1	1
Copper sulfate	3	3	2	2	2	1	3	na	1	1	na	1
Cottonseed oil	1	1	1	1	1	1	1	1	1	1	1	1
Creosote	1	1	1	1	3	1	1	1	1		1	1
Ethane	1	1	1	1	1	1	1	1	1	1	1	1
Ether	2	2	1	1	1	1	1	1	1	1	1	1
Ethyl chloride	3	3	1	1	1	1	1	1	1	1	1	2
Ethylene	1	1	1	1	1	1	1	1	1	1	1	1
Ethylene glycol	1	1	1	1	1	1	1	na	na	na	1	1
Ferric chloride	3	3	3	3	3	3	3	3	2	1	2	3
Formaldehyde	2	2	1	1	1	1	1	1	1	1	1	1
Formic acid		3	2	2	1	1	1	1	1	3	2	3
Freon wet	2	2	2	1	1	1	1	1	1	1	1	na
Freon dry	2	2	1	1	1	1	1	1	1	1	1	na
Furfural	1	1	1	1	1	1	1	1	1	1	1	2
Gasoline	1	1	1	1	1	1	1	1	1	1	1	1
Glucose	1	1	1	1	1	1	1	1	1	1	1	1
Hydrochloric acid, aerated	3	3	3	3	3	3	3	1	2	1-2	2	3
Hydrochloric acid, air free	3	3	3	3	3	3	3	1	2	1-2	2	3

# Technical Information

## Corrosion Resistance Table

### Rating Explanation

<b>1</b> Good	<b>2</b> Be careful
<b>3</b> Not useable	<b>na</b> No information

Fluid	Metal											
	Carbon Steel	Cast Iron	302 and 304 Stainless Steel	316 Stainless Steel	Bronze	Alloy20	Monel	Hasteloy B	Hasteloy C	Titanium	Cobalt base alloy 6	416 Stainless Steel
Hydrofluoric acid, aerated	2	3	3	2	3	2	3	1	1	3	2	3
Hydrofluoric acid, air free	1	3	3	2	3	2	1	1	1	3	na	3
Hydrogen	1	1	1	1	1	1	1	1	1	1	1	1
Hydrogen peroxide		1	1	1	3	1	3	2	2	1	na	2
Hydrogen sulfide, liquid	3	3	1	1	3	2	3	1	1	1	1	3
Magnesium Hydroxide	1	1	1	1	2	1	1	1	1	1	1	1
Mercury	1	1	1	1	3	1	2	1	1	1	1	1
Methanol	1	1	1	1	1	1	1	1	1	1	1	1
Methyl ethyl ketone	1	1	1	1	1	1	1	1	1		1	1
Milk	3	3	1	1	1	1	1	1	1	1	1	3
Natural gas	1	1	1	1	1	1	1	1	1	1	1	1
Nitric acid	3	3	1	2	3	1	3	3	2	1	3	3
Oleic acid	3	3	1	1	2	1	1	1	1	1	1	1
Oxalic acid	3	3	2	2	2	1	2	1	1	2	2	2
Oxygen	1	1	1	1	1	1	1	1	1	1	1	1
Petroleum oils	1	1	1	1	1	1	1	1	1	1	1	1
Phosphoric acid, aerated	3	3	1	1	3	1	3	1	1	2	1	3
Phosphoric acid, air free	3	3	1	1	3	1	2	1	1	2	1	3
Phosphoric acid vapors	3	3	2	2	3	1	3	1		2	3	3
Picric acid	3	3	1	1	3	1	3	1	1	na	na	2
Potassium chloride	2	2	1	1	2	1	2	1	1	1	na	3
Potassium hydroxide	2	2	1	1	2	1	1	1	1	1	na	2
Propane	1	1	1	1	1	1	1	1	1	1	1	1
Rosin	2	2	1	1	1	1	1	1	1		1	1
Silver Nitrate	3	3	1	1	3	1	3	1	1	1	2	2
Sodium acetate	1	1	2	1	1	1	1	1	1	1	1	1
Sodium carbonate	1	1	1	1	1	1	1	1	1	1	1	2
Sodium chloride	3	3	2	2	1	1	1	1	1	1	1	2
Sodium chromate	1	1	1	1	1	1	1	1	1	1	1	1
Sodium hydroxide	1	1	1	1	3	1	1	1	1	1	1	2
Sodium hypochloride	3	3	3	3	3	2	3	3	1	1	na	3
Sodium thiosulfate	3	3	1	1	3	1	3	1	1	1	na	2
Stannous chloride	2	2	3	1	3	1	2	1	1	1	na	3
Stearic acid	1	3	1	1	2	1	2	1	1	1	2	2
Sulfate liquor	1	1	1	1	3	1	1	1	1	1	1	
Sulfur	1	1	1	1	3	1	1	1	1	1	1	1
Sulfur dioxide, dry	1	1	1	1	1	1	1	2	1	1	1	2
Sulfur trioxide, dry	1	1	1	1	1	1	1	2	1	1	1	2
Sulfuric acid, aerated	3	3	3	3	3	1	3	1	1	2	2	3
Sulfuric acid, air free	3	3	3	3	2	1	2	1	1	2	2	3
Sulfurous acid	3	3	2	2	2	1	3	1	1	1	2	3
Tar	1	1	1	1	1	1	1	1	1	1	1	1
Trichloroethylene	2	2	2	1	1	1	1	1	1	1	1	2
Turpentine	2	2	1	1	1	1	2	1	1	1	1	1
Vinegar	3	3	1	1	2	1	1	1	1	na	1	3
Water, steam boiler feeding system	2	3	1	1	3	1	1	1	1	1	1	2
Water, distilled	1	1	1	1	1	1	1	1	1	1	1	2
Water, sea	2	2	2	2	1	1	1	1	1	1	1	3
Whiskey	3	3	1	1	1	1	2	1	1	1	1	3
Wine	3	3	1	1	1	1	2	1	1	1	1	3
Zinc chloride	3	3	3	3	3	1	3	1	1	1	2	3
Zinc sulfate	3	3	1	1	2	1	1	1	1			

SAFETY & ENVIRONMENT IS THE FIRST &  
MOST IMPORTANT



#### Products

- Crankcase Explosion Relief Valve
- Air Release Valve
- Air Release & Vacuum Breaker Valve
- Combination Air Release & Vacuum Breaker Valve
- Vacuum Breaker Valve
- Surge Relief / Control Valve
- Pilot Operating Pressure / Vacuum Valve
- Explosion Venting Devices
- VOC Emission Protection Devices

#### Application Fields

- Offshore & Ocean Gas Plants
- Desalination Plants
- Ballast System for Ships & Offshore Plants
- Sea & Fresh Water Plants
- Marine Tank Ships
- Cryogenic gas Facilities
- Petrochemical Plants
- Tank Terminals
- Marine Engines
- Generators
- Duct
- Water Supply Pipe Lines

ISO 9001 Registered

**PROSAVE CO., LTD.**