

D931 / D933 / D934

Fixed Orifice Double Regulating Valve (FODRV)



Features & Benefits

- D933 size 1/2" low flow FODRV combines the functions of regulation and flow measurement in a unit of high authority making it particularly suitable for low flow applications in the range of 0.03 to 0.07 l/s
- D934 size 1/2" ultra-low flow FODRV combines the functions of regulation and flow measurement in a unit of high authority making it particularly suitable for ultra-low flow applications in the range of 0.016 to 0.04 l/s.
- The Double regulating valve, with its integral fixed orifice design offers an accuracy of $\pm 5\%$ on all settings, for precise flow regulation and measurement
- The Double Regulating feature allows the valve to be used for isolation and to be reopened to its pre-set position to maintain required flow rate
- Y-Pattern globe valves having characterised throttling disc tending towards equal percentage performance
- Integral square edged entrance orifice plate and P84 insertion test points fitted Double regulating feature allows valve opening to be set with an Allen key
- Operation of the valve is by means of the Microset handwheel

Materials

PART	MATERIAL	SPECIFICATION
Body	Bronze	BS EN 1982 CC491K
Bonnet	DZR Copper Alloy	BS EN 12165 CW602N
Stem	DZR Copper Alloy	BS EN 12164 CW602N
Disc	DZR Copper Alloy	BS EN 12164/5 CW602N
O-Ring Seal	EPDM Rubber	
Orifice Insert	DZR Copper Alloy	BS EN 12164 CW602N
P84 Test Valve	DZR Copper Alloy	BS EN 12164 CW602N
Handwheel	Plastic	

Dimensional Drawing

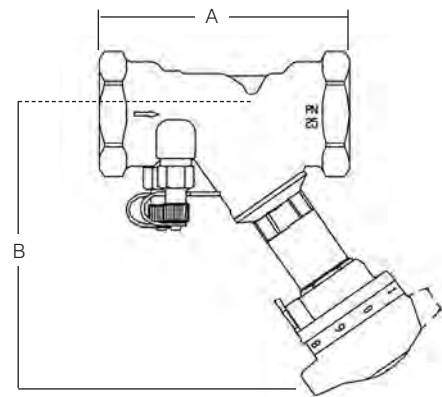

Dimensions, Coefficients & Weights

FIG. NO.	SIZE	DIMENSIONS (mm)		FULLY OPEN		KVS	WEIGHT (kg)
		A	B	FLOW (Kv)	HEAD LOSS (K)		
D931	1/2"/DN15	87	105	1.87	30.27	2.2	0.61
	3/4"/DN20	96	106	3.14	34.55	4.7	0.65
	1"/DN25	100	127	5.59	27.85	8.6	0.95
	1 1/4"/DN32	114	128	10.80	22.60	16.6	1.13
	1 1/2"/DN40	125	143	18.10	14.76	24.5	1.52
	2"/DN50	146	144	29.10	14.62	46.1	1.98
D933	1/2"/DN15	87	105	1.06	94.20	1.1	0.61
D934	1/2"/DN15	87	105	0.57	325.80	0.58	0.61

Pressure/Temperature Ratings

Threaded

TEMPERATURE (°C)	-10 to 100	110	120
PRESSURE (BAR)	25	23.4	21.8

Compression

TEMPERATURE (°C)	-10 to 30	65	120
PRESSURE (BAR)	16	10	5

Intermediate pressure ratings shall be determined by interpolation.

Maximum temperature 120°C.

Note: In line with BS EN 1254/2, the maximum pressure must not exceed 16 bar when using compression adaptors.

WRAS approved -10 to 85°C

SPECIFICATION: Conforms to BS 7350*:1990

END CONNECTIONS: Sizes 1" to 2" taper threaded to BS EN 10226-2 (ISO 7-1) formerly BS 21.

Sizes 1/2" & 3/4" DN15 & DN20 BS 2779 (ISO 228) parallel. Adaptor kits for use with copper tube also available.

Also available threaded to ANSI B1.20.1AT.

Order code D931AT/D933AT/D934AT.