

**Top Reliability, Smart Design,
Valuable Product and Better Life**

PROTECTION DEVICES

for SAFETY, ENVIRONMENT AND ENERGY

- Air release valve
- Combination air release and vacuum breaker valve
- Vacuum breaker valve
- Surge relief valve
- Breather valve
- Flame arrester
- Emergency vent cover
- Gauge hatch cover
- High velocity Pressure / Vacuum relief valve
- Vapor Emission Control System
- Crankcase Explosion Relief valve
- Flameless explosion venting devices
- Solar Water Distiller



PROSAVE

Overview

PROSAVE is always challenging and working as a pioneer to accomplish the unlimited possibility to the newest technology for Safety and Environment Protection devices of marine engine, petrochemical, on/off-shore plant & desalination plant.

PROSAVE has been trying to produce the best quality products with own technology and modern manufacturing facilities.

We supply high quality safety valve with state of the art technology from our modern manufacturing facilities.

To be the NO.1 company in the world where all of Our employees and their families are happy and their dreams can come true.

By producing the best products with passion and challenge spirit, contributing to the prosperity of the nation and the human welfare, and by satisfying the customers, creating the affluent and beautiful society.

We would like to appreciate for your patronage and wish to inform you our capabilities and products. Finally, We hope you will find this information helpful for your future Safety and Environment Protection plans.



Introduction

Enjoy your Job for your Health, with **PROSAVE's** Safety and Environment Protection Devices

Vision

To be the NO.1 company in the world where all of Our employees and their families are happy and their dreams can come true.
By producing the best products with passion and challenge spirit, contributing to the prosperity of the nation and the human welfare, and by satisfying the customers, creating the affluent and beautiful society.

Mission

Passionate Challenge! / Speedily! / Timely! / Do!

Organization

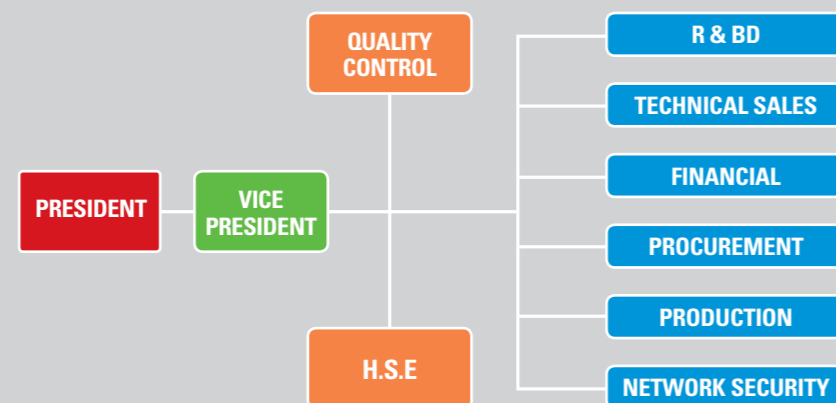

History

- 2010** _ Established PROAVE CO.,LTD.
- 2011** _ Established Institute of Technical Research & Development
 - _ Obtained ISO 9001 Certificate
 - _ Obtained Type Approval Certificates from MAN Diesel & Turbo, GL, DNV, BV, LR, ABS, RINA, KR, NK, CCS & RS for Crankcase Explosion Relief Valves
 - _ Obtained Patent of High Velocity Pressure/Vacuum Valves
 - _ Obtained Patent of Crankcase explosion relief valves
 - _ Selected to Enterprise for Venture
- 2011** _ Registered as vendor by HHI, DOOSAN, SHI, TORISHIMA PUMP, CTCI, STX,YMD, RMD, ALGHANIM, NIOC, SAMSUNG C&T, DAELIM INDUSTRIAL, BECHTEL, NIOEC
- 2012** _ Obtained Type Approval Certificates of MED(CE), DNV, ABS, LR, BV, GL, RINA, KR, NK, CCS & RS for Smart High Velocity Pressure/Vacuum Relief Valves
- 2013** _ USD 1 Million export tower award _ Obtained INNO-BIZ Certificates
- 2014** _ Registered as vendor by TAKREER
- 2015** _ USD 3 Million export tower award
- 2016** _ Registered as vendor by DSME, TOYO ENGINEERING, HITACHI, DIESEL UNITED, PETRONAS
- 2017** _ Moved to new facility (#115-22, Tekeunobaelli 1-ro, Jillye-myeon, Gimhae-si, Gyeongsangnam-do, Korea)
Registered as vendor by TECHNIMONT, PTTEP, MMHE, JACOBS, CB&I
- 2018** _ Registered as vendor by SCHLUMBERGER, K.O.C., ADNOC, DEWA, KHARAAMA, MHPS, DAIHATSU, HYUNDAE SAMHO HEAVY INDUSTRY, PUBLIC PROCURMENT SERVICES (KOREA).
 - _ Obtained Patent for Surge relief valve and Dust collector
 - _ Obtained Type approval certificate of DNV-GL, ABS, NK for New crankcase explosion relief valve
- PRESENT:** Challenging No. 1 Company for Safety & Environment protection for Off-shore, Marine, Petrochemical & Power & Desalination Plants

Air Release Valves, Air Release & Vacuum Breaker Valve, Combination Air Release & Vacuum Breaker Valve for Water Works System

The definition of a term

1. Air release valves, also called small orifice valves, are designed to automatically release small pockets of accumulated air from a pipeline while the system operates under pressure exceeding atmospheric pressure.
2. Air/vacuum valves, also called large orifice valves, are designed to exhaust large amount of air automatically during pipeline filling and to inflow large amount of air automatically when the internal pressure in the pipeline drops below atmospheric pressure.
3. Combination air valves are designed to perform the same function as air/vacuum valves but, in addition, they will automatically release small pockets of air from the pipeline while under pressure, like an air release valve.

Applied code

AWWA - C512 standard.
(American Water Works Association)



KSBJ



Air Release & Vacuum Breaker Valve

Benefits

- Pressure & Vacuum relief function
- Anti-Surge & Anti-Shocks
- Surge and waterhammer protection
- Liquid overflow protection
- Provides high capacity venting for pipeline protection
- Increasing pump efficiency
- Less system energy
- Maintenance free

CAV-D



Combination Air Release & Vacuum Breaker Valve

Additional Option for a variety of applications

KSBJ-C

Air release
& Vacuum Breaker
with Surge Check Valve



VB-AR

Vacuum Breaker
Valve with Air
Release Valve



Benefits

- Pressure & Vacuum relief function
- Anti-Surge & Anti-Shocks
- Surge and waterhammer protection
- Liquid overflow protection
- Provides high capacity venting for pipeline protection
- Increasing pump efficiency
- Less system energy
- Maintenance free
- Release small pockets under operation pressure

Vacuum Breaker Valve

Design, manufacture and test according to the API code.

The KSVB is designed to protect equipments against over vacuum.

It covers set vacuum from -150 mmW.C to -9,600 mmW.C.

Body material are available in Aluminium, Carbon steel, Stainless steel, and Ni-Al Bronze with various trims to suit individual requirements.

KSVB



Benefits

- Protect equipments against over vacuum
- Prevent air intake during normal operation
- Evaporative losses of product
- To help containing odorous and potentially explosive vapors.

Surge Relief Valves

SOLENOID VALVE OPERATING SRV-S-A/SRV-S-Y TYPE

Introduction

Model SRV-S-A/SRV-S-Y consists of a main valve, solenoid valve, air set. It is completely assembled and tested as a unit and ready for field installation. Main Valve is closed tightly when normal operation is in state. When excessive pressure is coming, surge command from pressure transmitter operates the solenoid valve, and then main valve is open for protecting for surge effect (Water hammer).



Typical Installation

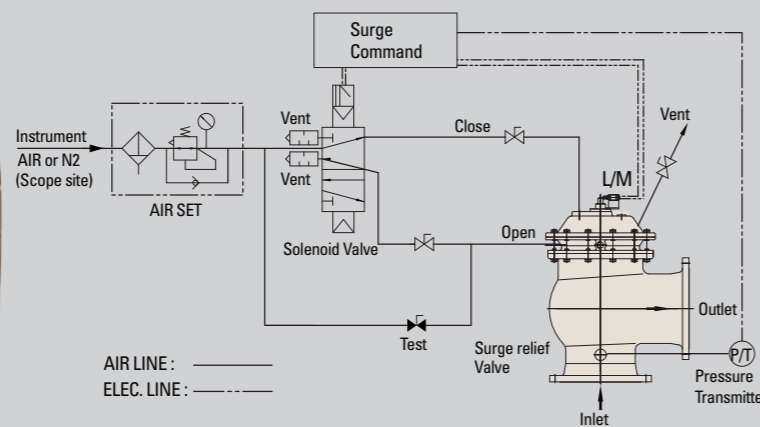

Benefits

Adjustable Opening and Closing Times

- In particular, Full opening time is less than 200 millisecond.
- Open and close time of SRV depends on field site.
- Quick open time and slight close time are adjustable.

Accurate and Precise Pressure Control

- Main valve of pressure control is provided by accurate and precise pressure of pneumatic solenoid valve.

Normal Open / Close Selectable

- SRV consists of solenoid valve, air receiver tank (optional) and air set. It enables Normal Open or Close of main valve.

Surge Relief Valves

N2 LOADED OPERATING SRV-N2-X TYPE

Introduction

N2 Loaded Surge Relief Valves are engineered to track unabated surge-wave pressure transients-open quickly, then closes without slamming shut. The "speed of response" in surge valves is defined as the ability of the valve/valves to relieve peak wave surge flow in the time stated in a hydraulic transient surge analysis. Although this time varies with each application, timed responses is less than 100 milliseconds

N2 Loaded Surge Relief Valve operation is simple. The cavity behind the valve disc is filled with nitrogen gas to affect proper relief set pressure of the valve. This cavity loading force seats the valve and opposes the force generated by line pressure in front of the valve. The valve remains closed until surge wave pressure exceeds the force behind the disc (set pressure).

N2 Loaded Surge Relief Valve then opens quickly to track the unabated surge wave. The closing cycle responds directly to pressure decay in the upstream piping in front of the surge relief valve.



Typical Installation

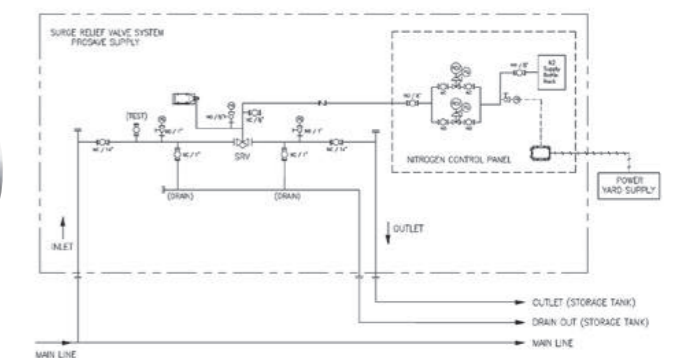

Benefits

High flow capacities

High flow capacities (Cv) mean you can use smaller and/or fewer valves to provide the surge protection you need. Save on installation cost and save weight.

Accurate and Precise Pressure Control

Response time is less than 100 millisecond.

Non-Slam

Fast response-rapid open/closing without slamming shut-allows the valve to "track the surge."

Surge Relief Valve

PILOT OPERATING SRV-P-A/SRV-P-Y TYPE

Introduction

Model SRV-P-A/SRV-P-Y consists of a main valve, low and high pilot valve, and accessories.

A pilot-operated control valve is a self-acting surge pressure relief valve used for backpressure, pressure reduction and pump bypass.

SRV-P-A/SRV-P-Y is installed in bypass pipeline to protect the piping system from the surge(Water hammer) by sudden flow change and pump sudden stop.

Main Valve is open when low pilot valve anticipates the negative pressure in piping system to prevent the pipe pressure rise, and when high pilot valve detects the exceed pressure in piping system to discharge pressure.

Main Valve is tightly closed when normal operation is in state.



Typical Installation

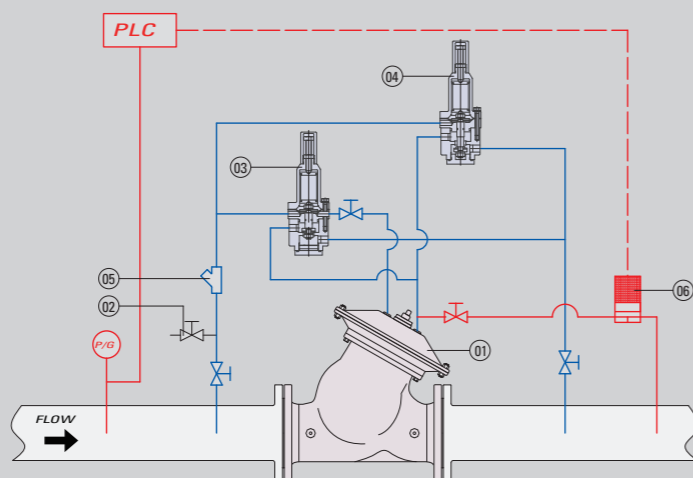

- 01 - Main valve 03 - High pressure pilot valve 05 - Strainer
- 02 - Vent valve 04 - Low pressure pilot valve 06 - Solenoid valve(Optional)

Benefits

No maintenance

Piping system allows use of pilot-operated control valves with little or no maintenance

No external power source

Self-contained pilot-operated valves require no external power source

Can be installed in a variety of piping configurations

Surge Relief Valve

MECHANICAL STAND-ALONE AXIAL SRV-M-X TYPE

Introduction

The SRV-M-X model can be installed in places where it can not supply power sources such as electricity or hydraulic pressure, such as underground or desert, or can not be maintained, and can be used in sewage or high-viscosity crude oil lines containing foreign matter.

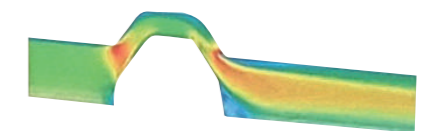

Velocity Distribution Result
(Using ANSYS CFD)

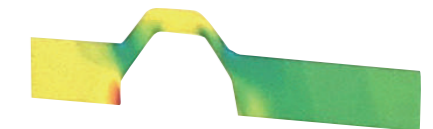

Pressure Distribution Result
(Using ANSYS CFD)

Benefits

All Fluids

Can be used for almost all fluids such as crude oil, contaminated water, sewage including sludge.

Quick Response Time

Valve response time is extremely important in controlling peak surges. SRV-M has response time less than 100 millisecond.

Large Flow Capacities

Since the shape of the flow path inside the valve is streamlined, the value of the flow coefficient Cv is larger than that of the other valves.

A large flow capacities means that smaller or fewer valves can be used to reduce installation costs and weight.

Accurate set pressure control

Set pressure of surge relief valve is controlled by precise pressure control through internal spring.

Breather Valve

BV/BS TYPE

Introduction

The model BV/BS pressure vacuum relief valves designed, manufactured and tested according to the API 2000 standard.

The model BV/BS pressure vacuum relief valves used to relieve excess pressure and vacuum that has generated in a tank.

To avoid product loss, BV/BS pressure vacuum relief valves are recommended for using at atmospheric storage tank.

The set pressure and relieving pressure shall be consistent with the requirements of the standard according to which the tank was designed and fabricated. The model BV/BS can be manufactured the range of pressure and vacuum setting form ± 22 mm W.C to ± 8000 mm W.C.

The model BV type is weight-loaded type with minimum setting ± 22 mm W.C and maximum setting ± 700 mm W.C.

The model BS type is spring-loaded type over weight loaded type.

The materials for BV/BS shall be selected for the stored-product service temperatures and pressures. Also, the materials should be compatible with the product stored in the tank and with any products formed in the vicinity of the relief valve during filling and discharge. Usually the materials are available in Aluminum, Carbon Steel, Stainless Steel grade 304, 316 and 316L to suit individual requirements.

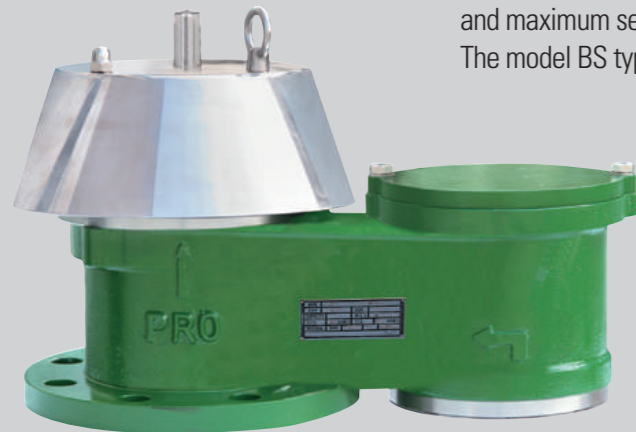

Benefits

- Designed according to the API 2000 standard.
- Less losses from reliable operation
- Suitable and compact design ensures long-term maintenance free life cycle
- Full lifting and high flow capacity
- Meet API leak test requirement
- No need inside maintenance
- Available outside inspection, cleaning and maintenance without disassembling

Pilot-operated Pressure/Vacuum Relief Valve

POV TYPE

General

Pressure and/or vacuum relief valves are used for dangerous oil, gas or petrochemical storage tanks and other process vessels or systems to prevent structural damage due to excess pressure or vacuum in.

Pilot-operated pressure/vacuum relief valves is performed best at applications, which it is required high amount of backpressure or fluctuating backpressure.

- Opting for modulating pilots allows the piston to lift only as high as is needed, venting off just enough pressure to prevent cycling (a common side effect of backpressure that can cause undue wear to valve parts).

Pilot operation is also recommended for equipments which low accumulation rates are required or when the set pressure level needs to be close to the operating pressure level.

- As pressure increases, the pilot maintains its seal tightly, allowing reliable operation closer to the set point for pack line, without product leakage.

- Pilot-operated pressure/vacuum relief valves can work at an operating pressure of up to 98% of set pressure.

Although their initial investment price tends to be higher, pilot-operated pressure/vacuum relief valves are much smaller than their spring-loaded counterparts, making them easier to install, maintain, and repair.



Benefits

- **PILOT OPERATED**
 - Easy settings
 - Only the pilot needs to be set
 - Lower profile and weight than spring operated types for high settings
 - Remote pilot sensing allows the pilot to sense the true system pressure (optional)
 - Remote or manual blowdown available
- **EXTRA TIGHT SEAL** - Main valve remains tight to set pressure
- **FULL FLOW** - Full open at 10% overpressure
- **SNAP-ACTION OR MODULATING ACTION**
 - Modulating action protect product since valve opening is proportional to overpressure.
 - Noise is reduced since the valve only opens fully when required.
- **SOFT SEATED** - Soft seats seal tight to protect product and minimize valve wear which improves reliability
- **TOP ENTRY** - Reduces maintenance costs since the valve can be completely serviced without removal from its mounting

Detonation Proof In-line Flame Arrester

ATEX and IMO Approved Explosion Proof In-line Flame Arrester



Introduction

The flame arrester is designed to prevent flame transmission when flammable gas/air- or vapor/air-mixtures are present.

The model FA in-line flame arrester is designed, manufactured and tested according to API 2000 and EN 12874.

Body material of arrester is available for nodular cast iron, cast steel, stainless steel grade 304, 316, 316L and special alloy steel for chemical resistance.

The material of element is available for stainless steel grade 316L or special alloy steel for chemical resistance.

The flame element is constructed with crimped ribbon metal.



Specification of gas/air-mixtures for deflagration and detonation tests(ISO 16852:2016)

Range of Application (Marking)		Requirement for test mixture	
Explosion group	MESG of mixture (mm)	Gas type	Gas in air by volume(%)
IIA	> 0.90	Propane	4.2 ± 0.2
IIB1	≥0.85	Ethylene	5.0 ± 0.1
IIB2	≥0.75		5.5 ± 0.1
IIB3	≥0.65		6.5 ± 0.5
IIB	≥0.50	Hydorgen	45.0 ± 0.5
IIC	< 0.50	Hydorgen	28.5.2 ± 2.0

MESG : Maximum Experimental Safe Gap

Benefits

- Type Approved by IMO and ATEX (European Directive 94/9/EC)
- Meet the latest international rule requirement of API 2000 and ISO 16852
- Protection against explosion and deflagration flame
- High flow capacity and minimum pressure loss
- Available bi-directional flow and flame passage
- Available vertical and horizontal installation
- Very easy maintenance for quick cleaning
- High performance chemical resistance material

Explosion Proof In-line Flame Arrester

EC-Type Examination Certificate N° FTZÚ 14 ATEX 0132X



Introduction

The flame arrester is designed to prevent flame transmission when flammable gas/air- or vapor/air-mixtures are present.

The model FA in-line flame arrester is designed, manufactured and tested according to API 2000, EN 12874 and ISO 16852.

Body material of arrester is available for nodular cast iron, cast steel, stainless steel grade 304, 316, 316L and special alloy steel for chemical resistance. The material of element is available for stainless steel grade 316L or special alloy steel for chemical resistance. The flame element is constructed with crimped ribbon metal.



Description of Protective System:

The in-line, bi-directional, deflagration flame arresters types FA-02; FA-03; FA-04; FA-05; FA-06; FA-08; FA-10; FA-12 are to prevent a flame transmission in case of deflagration of flammable gas - and/or vapour/air mixtures of the explosion group IIA, at a maximum operating pressure p_o , which is defined below and at maximum operational temperature of the flame arrester $T_o = +60^{\circ}C$. Flame arresters are consists of flame arrester element tight between two flanges.

Technical parameters:

Type of flame arrester	Size of flange connection	Ration Lu/D	Max. operation pressure p_o (absolute)	Operational temperature of flame arrester T_o	Explosion group
FA-02	DN 50 (2")	40	1.1 Bar	-20°C ≤ T _o ≤ +60°C	IIA
FA-03	DN 80 (3")	20	1.1 Bar		
FA-04	DN 100 (4")	20	1.1 Bar		
FA-05	DN 125 (5")	10	1.1 Bar		
FA-06	DN 150 (6")	10	1.1 Bar		
FA-08	DN 200 (8")	10	1.09 Bar		
FA-10	DN 250 (10")	10	1.09 Bar		
FA-12	DN 300 (12")	10	1.09 Bar		

Benefits

- Type Approved by IMO and ATEX (European Directive 94/9/EC)
- Meet the latest international rule requirement of API 2000, EN 12874 and ISO 16852
- Protection against explosion and deflagration flame
- High flow capacity and minimum pressure loss
- Available bi-directional flow and flame passage
- Available vertical and horizontal installation
- Very easy maintenance for quick cleaning
- High performance chemical resistance material

High Velocity Pressure / Vacuum Relief Valve with Gas Free Cover

SMART-HV TYPE



APPROVED
IMO MSC.1 / Circ, 1324 & MESG 0.65mm

Changed IMPORTANT REGULATIONS

NEW IMO Regulation for Product & Chemical carriers, MSC.1/Circ,1324

1. The Maritime Safety Committee approved the following amendments to MSC/Circ.677:
2. Member Governments are invited to apply the amendments to the Revised standards, as amended, to ships constructed on or after 1 January 2013 and to ships constructed before 1 January 2013, no later than the first scheduled dry-docking carried out on or after 1 January 2013.

Benefits

- Reliable operations reduces vapor losses
- Suitable and compact design ensures long-term maintenance free life cycle
- Meet new IMO & MED requirements for cargo vapor flammability - MESG 0.9 & 0.65 mm
- Non-oscillating performance
- Full lifting and high flow capacity
- Variable application for usable installation vent pipe length and flow capacity range
- No peak pressure over opening pressure
- No need inside maintenance
- Available outside inspection, cleaning and maintenance without disassembling
- Adjustable outside opening and closing pressure without exhausting vapor gas

Vapor Emission Control System

VECS TYPE



Introduction

- The VECS is installed on the mast riser's bypass line, and controls the vapor pressure in all cargo tanks during voyage for direct emission control, in order to reduce VOC loss from the tanks during voyage. By controlling the pressure in the venting system, it is possible to fully control the VOC emissions.
- To meet this challenge, a VECS and Reporting System can be used to control the vapour pressure in oil cargo tanks to minimise and fully control VOC emissions. Designed to comply with the latest international rules and regulations it is equipped with an advanced reporting system.

Rules & regulations

- SOLAS 74 Chapter II-2 Reg. 59. : Venting, purging, gas-freeing and ventilation.
- IMO MSC/Circ. 731. : Revised factors to be taken into consideration when designing cargo tank venting and gas-freeing arrangements.
- IMO MSC/Circ. 680. : Systems and Operations/VOC Management plans
- USCG CFR 46 Part 39. : Vapor control system.
- ISO 15364:2007 : Ships and marine technology - pressure/vacuum valves for cargo tanks.

Benefits

- Remotely controlled opening/closing from C.C.R (Cargo Control Room)
- Setting value
 - Opening pressure & Closing pressure : 1,700mmW.G ~ 1,500mmW.G (adjustable)
 - Opening vacuum & Closing vacuum : -200mmW.G ~ -100mmW.G (adjustable)
- Full open/close remotely by manual operation
- The emission of V.O.C can be automatically controlled during the voyage.
- Emitted V.O.C flow rate can be recorded.
- Explosion proof approved electric actuator (EX d IIB T4)
- Electric power source : AC 220V, 1Ph, 60Hz
- Signal : 4~20mA DC input.
- Linear actuator on request

Crankcase Explosion Relief Valve

N-ERV SERIES

Rule and QC Specification being applied

IACS

- IACS UR M66 Type testing procedure for Crankcase Relief Valve
- IACS UR M9 Crankcase Explosion Relief Valves for crankcase of internal combustion engines
- IACS UR M10 Protection of internal combustion engines against crankcase explosion

MAN Diesel Quality Specification

Quality Specification No. 0742838-0 (Crankcase Relief Valve)
 Production Specification No. 0742839-2 (Function Test of Relief Valve)
 Quality Control No. 0742827-2 (Control of Sub-suppliers)

Safety is our top priority at PROSAVE

PROSAVE's quality assurance system complies with the latest ISO 9001 provision.
 PROSAVE explosion relief valves have received top mark in numerous explosion tests conducted by the FTZU institute and type approved by DNVGL, KR, LR, ABS, CCS, RS, BV, NK, RINA and MAN-ES.



International patent pending

- IACS UR M66 & M9 Type Testing Procedure for Crankcase Explosion Relief Valve
- MAN Diesel Quality Specification

Benefits

- Quick opening and fully relieving pressure.
- Responding and opening even at a very low pressure setting
- No flame escape to outside.
- Due to absolute tightness after opening and closing, it prevents from secondary explosion.
- Can be installed in all mounting position from vertical to horizontal.
- It is light weight and small volume for easy installation and maintenance.
- Free area of flame arrester is enough wide and similar relief area.
- Closes and seals immediately after an explosion.

Flameless explosion relief valves

EVD SERIES

Introduction

To avoid a dangerous pressure rise and resultant damage when an explosion occurring in exhausts and inlet manifold. It is necessary to provide pressure relief valves of an enough relief area. This valve is suitable for high temperature applications up to 700°C and high pressure up to 6 barg.

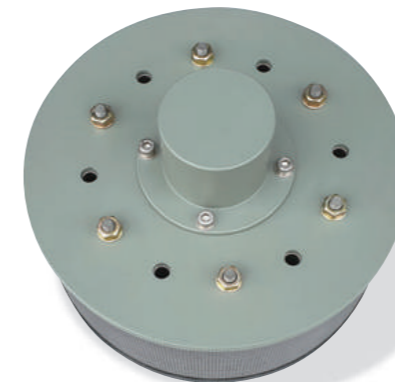

EVDM TYPE

FOR INLET/EXHAUST MANIFOLD OF DF OR GAS ENGINES

EVDM Series is mounted on the inlet manifold of the DF ENGINE or GAS ENGINE. If the explosion occurs during the movement of the gaseous fuel from the inlet manifold to the inside of the cylinder, explosion pressure can be discharged, and flame can be blocked and automatically distinguished by flame arrester element for prevention of the man and important facilities.



EVDD TYPE

FOR EXHAUST DUCT OF DF OR GAS ENGINES

EVDD Series is mounted on the exhaust duct of DF ENGINE or GAS ENGINE. When an explosion occurs by unburned gas fuel in the exhaust lines, explosion pressure can be discharged by EVDM, and flame can be blocked and automatically distinguished by flame arrester element for prevention of the man and important facilities.

Benefits

- Automatic re-closing structures against rupture disc (non re-closing devices)
- No need engine shut-down.
- Very high capability seat tightness.
- Available continuously engine operation.
- Prevention of secondary explosion.
- Protection of man and key components due to explosion.
- Discharging protection of unfired and/or burned mist, gas, ashes and dust, into engine.
- Protection devices for Health, Safety and Environment.
- Available IoT options

Quality Control Activities

Certificate

Company Overview

The company is a manufacturer of safety valve for tank, we strive to comply and maintain the quality manual to increase development of new technology, enhance product quality and productively while reducing costs.

Scope of Application

This manual was established based on the regulations of ISO 9001 : 2000 / ISO 14001:2004 and applies to design, development, sales, procurement, manufacturing, inspection, service department and overall organizations.

Definition of Terminology

The terminology relating to quality management system in the quality manual are as defined in ISO 9001:2015 / ISO 14001:2015

Approved Classification

- QUALITY MANAGEMENT SYSTEM ISO 9001:2015 / ISO 14001:2015
- MAN Diesel & Turbo
- AMERICAN BUREAU OF SHIPPING (ABS)
- Bureau Veritas (BV)
- LLOYD'S REGISTER OF SHIPPING (LR)
- DET NORSKE VERITAS (DNV-GL)
- NIPPON KAIJI KYOKAI (NK)
- KOREA REGISTER (KR)
- CHINA CLASSIFICATION SOCIETY (CCS)
- REGISTRO ITALIANO NAVALE (RINA)



Worldwide sales & service network



Major Customer

Domestic Market

- HYUNDAI HEAVY INDUSTRIES CO., LTD.
- DAEWOO SHIPBUILDING & MARINE ENGINEERING CO., LTD.
- DOOSAN HEAVY INDUSTRIES CO., LTD.
- STX Heavy Industries Co., Ltd.
- STX Offshore & Shipbuilding Co., Ltd.
- GS E&C CO.,LTD.
- HYUNDAI SAMHO HEAVY INDUSTRY
- KOGAS
- ETECH ENGINEERING
- WÄRTSILÄ-HYUNDAI ENGINE CO., LTD.
- SAMSUNG HEAVY INDUSTRIES CO., LTD.
- HANWHA E&C CO.,LTD.
- DAEWOO E&C CO.,LTD.
- HYUNDAI E&C CO., LTD.
- SK E&C CO.,LTD.
- DAELIM INDUSTRIAL CO., LTD.
- SAMSUNG C&T CORPORATION

Overseas Market

- TOTAL
- CHEVRON
- SHELL
- EXXONMOBIL
- SAIPEM S.p.A
- BP
- TORISHIMA PUMP MFG. CO., LTD.
- RELIANCE
- MITSUBISHI HITACH POWER SYSTEM
- ADNOC GROUP
- SCHLUMBERGER
- KHARAAMA
- TECHNIP FMC
- CTCI COPORATION
- K.O.C
- PETRONAS
- ASL SHIPYARD
- MCDERMOTT
- SADARA CHEMICAL COMPANY
- KEPPEL
- BW OFFSHORE
- PTTEP
- MMHE
- BETCHTEL
- TOYO ENGINEERING
- MITSUBISHI HI
- MISHUI ENGINEERING & SHIPBUILDING
- CHIYODA
- HITACHI ZOSEN
- MODEC OFFSHORE PRODUCTION SYSTEMS
- ORASCOM E & C USA
- UTE TSGI
- PETRONAS
- MAIRE TECNIMONT
- RONG'AN MARINE DIESEL
- DIESEL UNITED
- SHAANXI DIESEL & MARINE
- DALIAN MARINE DIESEL
- YICHANG MARINE DIESEL